



## VL SINGLE SCALING HAMMERS



## OPERATION & MAINTENANCE



**TRELAWNY**<sup>TM</sup>

SURFACE PREPARATION TECHNOLOGY

[www.trelawnyspt.com](http://www.trelawnyspt.com)

# OPERATION

## General Information

Before operating Trelawny Vibro Lo Scaling Hammers, this manual must be read and understood by the operator, if in any doubt, ask your supervisor before using this equipment. Local safety regulations must be followed at all times. Failure to follow these instructions could result in damage to the Scaler and/or personal injury.

Trelawny SPT Ltd disclaims all responsibility for damage to persons or objects arising as a consequence of incorrect handling of the tool, failure to inspect the tool for damage or other faults that may influence its operation prior to starting work, or failure to follow the safety regulations listed or applicable to the job site.

The Standard Vibro Lo scaling tool is fitted with taper fit cutter heads and is primarily designed for the removal of heavy rust and scale.

The Heavy-Duty Vibro Lo one piece piston with TCT cutter version is suitable for concrete reduction and the removal of laitance from concrete.

**Note:** Cruciform headed pistons are best suited for the removal of heavy rust and scale and also for the reduction of concrete where a smoother finish is required; these will reduce the aggregate as well as the concrete surface.

Bush Hammer style headed pistons are best suited to concrete reduction and for laitance removal; these reduce the damage caused to the aggregate using the cruciform cutter head, ensuring that a strong bond is created with the next layer.

## Air Supply

The compressed air must be free from water and dirt. The installation of a filter/regulator/lubricator air preparation set (with moisture trap) adjacent to the tool is strongly recommended.

Always clear the air hose before connection to the tool. Ensure that no moisture (condensation) is present in the air hose.

Ensure that a minimum 10mm (3/8") bore air hose is used and that all couplings are secure, leak free and in good condition.

Limit the length of air hose to 10M (33ft). Where extra length is necessary, for each additional 15M (50ft) of air hose used, the pressure drop is approximately 0.16bar (3psi).

**Correct operating pressure is 6.2bar (90 psi).**

Do not let the operating pressure fall below 5.5bar (80p.s.i.) or rise above 6.9bar (100 psi).

The compressor must be able to supply a minimum of 7.08 lps (15cfm), (Free air, not displaced as quoted by some compressor manufactures).

In particularly cold weather it is recommended that a proprietary anti-freeze lubricating oil is used.

## Safety

Always, read instructions first before use.

**Do** wear Personal Protective Equipment including safety goggles, footwear, ear defenders and gloves. In some environments it will be necessary to wear facemasks or breathing apparatus.

**Do** be aware that this tool is not electrically insulated.

**Do** keep hands and clothing away from moving parts.

**Do** ensure that this tool is lubricated daily.

**Do** be aware that the tool can create dust and flying debris.

**Do** be aware of others working around you.

**Do** store this tool in a secure and dry environment.

**Always observe safe-working practices at all times.**

**Do not** allow the tool to run unattended.

**Do not** use this tool in potentially explosive environments.

**Do not** drag this tool by the air hose.

**Do not** use the Scaler as a lever.

**Do not** use petrol (gasoline), thinners or any other high flash point solvent to clean the tool.

**Do not** modify this tool in any way, as this will invalidate the warranty and could lead to serious injury.

## Risk of Hand-arm Vibration injury

These tools may cause Hand-arm Vibration Syndrome injury if their use is not adequately managed. We advise you to carry out a risk assessment and to implement measures such as; limiting exposure time [i.e. actual trigger time, not total time at work], job rotation, ensuring the tools are used correctly, ensuring the tools are maintained according to our recommendations, and ensuring that the operators wear personal protective equipment [PPE] **particularly gloves and clothing** to keep them warm and dry.

Employers should consider setting up a programme of health surveillance to establish a benchmark for each operator and to detect any early symptoms of vibration injury.

We are not aware of any PPE that provides protection against vibration injury by attenuating vibration emissions.

**See 'Specifications' section for vibration emission data.**

Further advice is available from our Technical Department.

## Recommended lubricants

Oil the tool daily before use. Put a few drops of one of the following zinc free air tool lubricants through the air inlet.

SHELL	S22 or R10
CASTROL	Hyspin ZZ32

## Cleaning

At intervals of no more than 40 hours or if operation becomes unproductive and the piston shows signs of sticking, dismantle and clean with a highly refined paraffin.

Immediately after cleaning, thoroughly oil the tool with one of the recommended lubricants.

## Starting work

Prior to operating the tool check: -

That all fittings are secure, free from leaks and air hoses are in good condition.

That the air pressure is correct for this tool 6.2 bar (90p.s.i.). Put a few drops of recommended lubricant into the air inlet of the tool. To operate the tool, which is dependant on the type of lever fitted, for those fitted with a safety lever, first push thumb button forwards and then for both styles of lever, pull the lever towards the handle grip to start the tool, then apply the cutter heads to the surface being prepared.

**To switch off, simply release the throttle lever.**

Care must be taken to avoid damaging or tripping over the air hose. Maintain contact with the work surface with sufficient pressure only to keep the tool from bouncing off. Excessive pressure can prevent the tool from working to its full capacity. Handled correctly the Scaler will work quickly and efficiently.

**Excessive operator pressure will not improve the tool efficiency but will cause premature tool failure and operator fatigue.**

# MAINTENANCE

Never allow the tool to run continuously whilst not in contact with the surface being prepared.

**Please be aware:** that this tool will reduce in power or stop working if the end cap (20) has become unscrewed.

## Maintenance

Maintenance must only be carried out by a competent person.

**Disconnect the tool from the air supply before carrying out any of the following operations.**

Clean all debris from the exterior of the tool.

### Head removal - Taper Fit (On site)

Lay the scaling hammer on a solid surface with the cutter head (21) facing uppermost. Place the head removal washer (23) between the cutter head and the body; insert the removal pin (22), into cutter head hole (refer to diagram for pictorial illustration). Wearing safety glasses, using a medium size hammer give a sharp blow to the head of the pin, which will release the cutter head from the piston.

### One Piece Piston & Piston/Cylinder Assembly removal (Workshop)

Hold the single scaler body (14) in a vice, using the flats provided and with the end cap uppermost. Unscrew the end cap (20). Remove spring cap (18) and spring (19) from the end cap. From the bottom of the body, push up the cutter head to remove the piston assembly.

### Head removal - Taper Fit (Workshop)

Lay the piston and cylinder assembly on a solid surface with the cutter head facing uppermost. Place the head removal washer (23) between the cutter head and the cylinder; insert the removal pin (22), into cutter head hole (refer to diagram for pictorial illustration). Wearing safety glasses and using a medium size hammer, give a sharp blow to the head of the pin, which will release the cutter head from the piston. Inspect all components for wear, replace as necessary.

### Valve body servicing (Workshop)

Clamp the assembly firmly in a soft face jawed vice, using the flats provided on the valve body, with the throttle lever upper most. Using a 3mm diameter pin punch, remove the throttle lever roll pin (8), and then remove the throttle lever (7). Rotate the tool 180 degrees in the vice to access the valve. Unscrew the valve cap (1) using a screwdriver, check the valve cap's 'O'Ring (2). Remove the spring (3).

Remove the valve stem (4) and the valve seat 'O' Ring (5). Check the valve stem and 'O'Ring for wear.

### Assembly (Workshop)

Before any assembly takes place, ensure all parts are clean and have a film of air tool oil lubrication unless otherwise stated. Avoid lubricating oil or grease contaminating the threads of the end cap (20), the threads within the bore of the body (14) and also the taper of the piston and cutter head. The end caps will require securing with a thread-locking adhesive. It is good practice to renew the O' Rings (2 & 5) and the brush seal (15). Replace any parts showing signs of wear; paying particular attention to the small bore of the cylinder.

### Valve Body assembly (Workshop)

Clamp the assembly firmly in a soft face jawed vice, using the flats provided on the valve body, insert new valve stem 'O'Ring (5) into valve body (6), followed by the valve stem (4), spring (3), then the valve cap (1) complete with its O'Ring (2), tighten the valve cap with a screwdriver. Rotate assembly 180 degrees in vice. Using a 3mm diameter pin punch locate and align the throttle lever (7) in position, then drive in the throttle lever roll pin (8) into the pin location.

### Head Assembly - Taper Fit (On-Site)

Thoroughly clean the cutter head and piston. Remove all traces of debris/oil from the taper on the piston (17) and the internal taper of the cutter head (21) by cleaning with suitable oil free solvent. Place the tool in a position where the end cap is on a solid surface; Fit a new and cleaned cutter head and place on to the taper of the piston. Using a soft-faced hammer deliver a sharp blow to the cutter head. (Using a hard faced hammer may cause the tungsten carbide inserts to chip or shatter which could cause a serious injury to you).

### Head Assembly - taper fit (Workshop)

Remove all traces of oil and dirt etc, from the taper on the piston (17) and cutter head (21) by cleaning with suitable oil free solvent. Fit the piston into the cylinder (16) as shown in the service layout.

### Flexible Connector

If the Flexible Connector (12) requires replacement, return the tool to you local distributor who will arrange for a new connector to be fitted. These connectors are fitted with unique retaining clips (13) and a special machine is required to fit them. **Do not** replace with a similar hose or Jubilee type clips, this could be dangerous to the operator and will not produce the same vibration reduction characteristics.

Place the assembly onto a solid surface; fit a new brush-seal (15) over the piston and into the recess of the cylinder.

Select one of the cleaned new cutter head and place on to the taper of the piston.

Using a soft-faced hammer deliver a sharp blow to the cutter head.

**Note:** If you are re-fitting a used cutter head to the piston it is essential that the internal diameter of the cutter head is re-surfaced using a medium grade of emery cloth - this will ensure a good fit between cutter head and piston, do not use adhesive of any description on the taper.

If the taper has expanded to much on the old cutter heads, they may not stay on the piston, and replacements will be required.

### One Piece Piston and Piston/Cylinder assembly (Workshop)

Lubricate the piston (17a) and cylinder bore(16a) and push the piston into the cylinder bore.

## FINAL ASSEMBLY

### Both types (Workshop)

Lay the tool on a bench with the body (14) on its side and insert the cylinder assembly into the body and apply a few drops of air tool lubricant to the top of the piston.

Hold the body (14) in a **soft faced** vice ensuring the screw cap threads are uppermost.

Assemble the end cap (20), fit spring (19) into the recess in the end cap and then fit spring cap (18) into the end cap as shown in the service layout.

Remove all traces of oil from the end cap threads and the threads of the body by cleaning with suitable oil free solvent.

Apply a bead of Loctite 243 sealant to the first 3 threads of the end cap.

Screw end cap assembly into the body until finger tight and using a suitable spanner torque down to 55N.m. (40 lbs.ft).

## DISPOSAL

When the tool and its accessories are taken out of service for disposal, it is recommended that: -

They are rendered unusable to prevent improper re-use.

They are dismantled into component form, segregated according to material composition and disposed of using waste recycling processes specified by local regulations.

# EXPLODED DIAGRAM

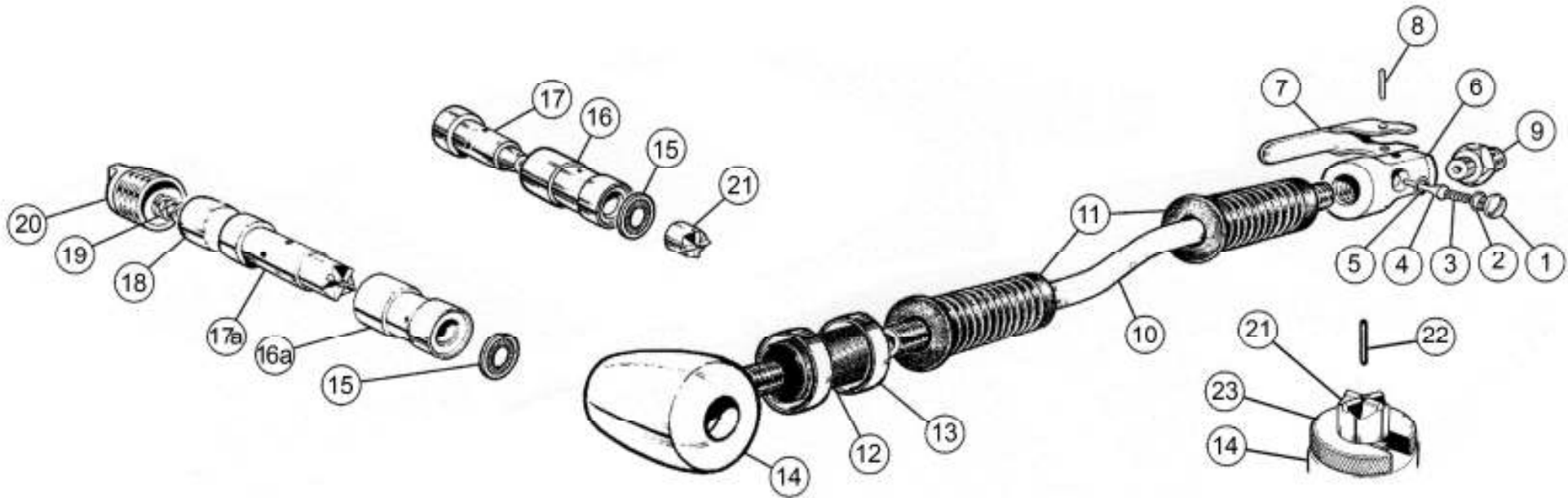

Item	Part Number	Description	Item	Part Number	Description
1	615.3021	Valve Cap	15	614.5301	Brush Seal
2	809.0139	O'Ring - Valve Cap	16	613.5301	Cylinder - (Standard Duty)
3	712.3022	Valve Spring	16a	613.5303	Cylinder - (Heavy Duty)
4	618.3022	Valve Stem	17	612.5301	Piston - (Standard Duty)
5	809.0089	O'Ring - Valve Seat	17a	612.5320	Piston One Piece (Heavy Duty) - TCT Cruciform
6	616.5321	Valve Body		612.5325	*Piston One Piece (Heavy Duty) - TCT Bush Hammer
	423.5321	*Valve Body Assembly (inc 1-8)	18	615.5361	Spring Cap
7	716.3000	Throttle Lever	19	712.5301	Spring
	716.1000	*Throttle Lever Safety	20	615.5341	Screwed Cap
8	813.0108	Roll Pin	21	426.5351	Cutterhead (Standard Duty) - TCT Cruciform
9	427.5361	Adapter		426.5352	*Cutterhead (Standard Duty) - TCT Bush
10	624.5350	Tube Handle		606.5303	*Cutterhead (Standard Duty) - Beryllium Cruciform
11	717.5301	Rubber Grip	22	827.0428	Taper fit Cutterhead Removal Pin
12	719.1380	Flexible Connector	23	633.5301	Taper fit Cutterhead Removal Washer
13	821.2000	Hose Clamp			
14	411.5121	Body (Standard & Heavy Duty)			*Items not shown on exploded diagram

# TECHNICAL SPECIFICATIONS

	Standard Duty (Replaceable Cutterheads)	Heavy Duty (One Piece Piston)
Piston Diameter	27mm (1.06)	
Piston Length	68.8mm (2.70")	111.75mm (4.4")
Piston Stroke	26.0mm (1.023")	
Blows Per Minute	3000	2900
Air Consumption	3.3lps (7.0cfm)	4.25 lps (9 cfm)
Air Pressure	6.2 bar (90 psi)	
Length	472mm (18.6")	
Working Height	140mm (5.5")	160mm (6.3")
Weight	2.46 (5.42lbs)	2.49kg (5.49lbs)
Noise Level $L_{pA}$ dB (A)	92.5	90.9
$L_{wA}$ dB (A)	106.3	104.5
Vibration Level (Trigger Hand) Primary	3.7m/s <sup>2</sup> (k+ 0.0% +40%)	4.5m/s <sup>2</sup> (k= -0.0% +40%)
Secondary	9.9m/s <sup>2</sup> (k+ 0.0% +40%)	9.4m/s <sup>2</sup> (k= -0.0% +40%)

Declared vibration emission value are in accordance with BS EN 12096: 1997  
 (K) Equals the factor of uncertainty, which allows for variations in measurement and production.  
 Vibration data figures are tri-axial, which gives total vibration emission.

#### Risk of Hand Arm Injury

Because of various factors, the range of vibration emission during intended use of these tools is expected to be between 3.7m/s<sup>2</sup> – 13.16m/s<sup>2</sup>.  
 The vibration is dependent on the tool model, task, the operators grip, and feed force employed etc.

Noise level measured in accordance with: EN ISO 15744: 1999  
 Vibration measured in accordance with: BS EN ISO 8662 Parts 1 & 14 and BS EN ISO 5349-1: 2001, BS EN ISO 5349-2: 2002

#### Machinery Directive Information

This machine has been designed and produced in accordance with the following directives: **2006/42/EC Machinery Directive**

Trelawny tools are thoroughly tested under specified conditions in accordance with applicable internationally recognised standards. When a tool is used on site the conditions may not be the same as those used in our tests.

Trelawny Surface Preparation Technology operates a policy of continuous product development and refinement and therefore reserves the right to change technical specifications and product designs without giving prior notice.

© Copyright 2007, Trelawny SPT Limited, CV31 1XT. UK All rights reserved. Any unauthorised use or copying of the contents or part thereof is prohibited. This applies to trademarks, model denominations, part numbers and drawings.  
 Use only genuine Trelawny spares.

**The use of non-Trelawny spare parts invalidates the warranty.**



Trelawny SPT Limited  
 Trelawny House, 13 Highdown Road, Sydenham Industrial Estate,  
 Leamington Spa, Warwickshire, CV31 1XT, United Kingdom  
 Telephone: +44 (0)1926 883781 Fax: +44 (0)1926 450352 Email: sales@trelawny.co.uk  
 General Industry Website: www.trelawnyspt.com  
 Dedicated Marine Website: www.trelawny-marine.com