



LONG REACH SCALERS



OPERATION & MAINTENANCE



TRELAWNYTM

SURFACE PREPARATION TECHNOLOGY

www.trelawnyspt.com

OPERATION

General Information

Before operating, performing maintenance or repairing the Long Reach Scaler this manual must be read and understood by the operator, if in any doubt, ask your supervisor before using this equipment.

Local safety regulations must be followed at all times. Failure to follow these instructions could result in damage to the Scaler and/or personal injury.

Trelawny SPT Limited disclaims all responsibility for damage to persons or objects arising as a consequence of incorrect handling of the tool, failure to inspect the tool for damage or other faults that may influence the operation prior to starting work, or failure to follow the safety regulations listed or applicable to the job site.

The tool is primarily designed for the removal of workshop soiling, solidified paint spills, carpet and ceramic tile removal, heavy rust, and scale, concrete splashes and ; it can also be used for the removal of laitance from concrete.

This tool can be purchased in either Needle Scaler or Chisel Scaler versions, with an adaptor available for converting from one version to another. It can be used both indoors and out.

Air Supply

The compressed air must be free from water and dirt. The installation of a filter/regulator/lubricator air preparation set (with moisture trap) adjacent to the tool is **strongly recommended**.

Always clear the air hose before connecting to the tool. Ensure that no moisture (condensation) is present in the air hose.

Ensure that a minimum 10mm (3/8") bore air hose is used and that all couplings are secure, leak free and in good condition.

Limit the length of air hose to 10M (33ft). Where extra length is necessary, for each additional 15M (50ft) of air hose used, the pressure drop is approximately 0.21bar (3psi).

For safe and efficient operation the correct operating pressure is 6.2bar (90 psi).

Do not let the operating pressure fall below 5.5bar (80p.s.i.) or rise above 6.9bar (100 psi). Preferably, the compressor should be able to supply a minimum of 2.8 L/s (6 cfm).

In particularly cold temperatures it is recommended that a proprietary anti-freeze lubricating oil is used.

Lubrication

Oil the tool daily before use. Put a few drops of one of the following zinc free air tool lubricants through the air inlet.

SHELL	S22 or R10
CASTROL	Hyspin ZZ32

See also the section on AIR SUPPLY for further information and recommendations.

Safety

Always, read through these instructions first before use.

Do-

Be aware that this tool is not electrically insulated.

Wear Personal Protective Equipment including safety goggles, footwear, ear defenders and gloves. In some environments it will be necessary to wear facemasks or breathing apparatus.

Be aware that this tool can create dust and flying debris.

Keep hands and clothing away from moving parts.

Store this tool in a secure and dry environment.

Be aware of others working around you.

Ensure that this tool is lubricated daily.

Always observe safe-working practices at all times.

Do not-

Allow the tool to run unattended.

Modify this tool in any way, as this will invalidate the warranty and could lead to serious injury.

Allow the tool to run continuously whilst not in contact with the surface being prepared.

Use the tool if you become tired, this can lead to physical strain or injuries.

Hold the exposed chisel or needles whilst the tool is in use, this could cause vibration damage to the hands.

Use this tool in potentially explosive environments.

Drag this tool by the air hose.

Use petrol (gasoline), thinners or any other high flash point solvent to clean the tool.

Care must be taken to avoid damaging or tripping over the trailing air hose.

Please note: Unrestrained hoses can whip dangerously if they become detached.

Risk of Hand-arm Vibration injury

These tools may cause Hand-arm Vibration Syndrome injury if their use is not adequately managed.

We advise you to carry out a risk assessment and to implement measures such as:

Limiting exposure time [i.e. actual trigger time, not total time at work], job rotation, ensuring the tools are used correctly, ensuring the tools are maintained according to our recommendations, and ensuring that the operators wear personal protective equipment [PPE] particularly gloves and clothing to keep them warm and dry.

Employers should consider setting up a programme of health surveillance to establish a benchmark for each operator and to detect early symptoms of vibration injury.

We are not aware of any PPE that provides protection against vibration injury by attenuating vibration emissions.

See 'Specifications' section for vibration emission data.

Further advice is available from our Technical Department.

We strongly advise you to visit the Health & Safety Executive website <http://www.hse.gov.uk/vibration> This site provides excellent advice and information on HAV and it includes a Hand-arm Vibration Exposure Calculator that is easy to use to work out the daily vibration exposure for each of your operators.

Starting work

Please note:

The carbon steel chisels or needles provided with these tools are not intended for use in a potentially explosive atmosphere.

Prior to operating the tool check: -

That all fittings are secure, free from leaks and air hoses are in good condition.

That the air pressure is correct for this tool 6.2 bar (90 p.s.i.).

Put a few drops of a recommended lubricant into the air inlet of the tool.

To operate the tool, which is dependant on the type of lever fitted, for those fitted with a safety lever, first push thumb button forwards and then for both styles of lever, pull the lever towards the hand grip to start the tool, then apply the Chisel or Needles to the surface being prepared.

Note: Several types of Chisel are available for the Long Reach Chisel Scaler to suit the job in hand, including Aluminium Bronze spark resistant Chisels; a Needle Scaler Attachment is also available.

See parts list for details.

Warning! This tool will continue to run for a few seconds after releasing the throttle lever; it is recommended that the tool remains in contact with the work surface until the air is exhausted. Gloves and personal protective equipment must be worn when using this tool. (See previous section on Risk of Vibration Injury). Care must be taken to avoid damaging or tripping over the air hose. Maintain contact with the work surface with sufficient pressure to keep the tool from bouncing off the surface. Handled correctly the Long Reach Scaler will work quickly and efficiently.

To switch off, simply release the throttle lever.

Safe use of this tool requires a solid stance and secure foothold, the tool may be used in other postures but care must be taken to ensure the operator adopts a firm and stable position. Excessive operator pressure will not improve the tools efficiency but could cause premature tool failure and increase operator fatigue. It could also increase the vibration emission level.

Never allow the tool to run continuously whilst not in contact with the surface being prepared.

Do not use the Scaler as a lever, if the Chisel becomes embedded in the material, withdraw and try again. Never allow the tool to run continuously whilst not in contact with the surface being prepared.

MAINTENANCE

Chisels

Various sizes and types of Chisel are available.
See parts list for details.

Fitting of Chisel Holder

Before fitting the Chisel Holder (31), disconnect the tool from the air supply.

To fit the Chisel Holder (31) ensure that the pinch bolt (30) on the Chisel Holder is loose, screw the Chisel Holder fully on to the Cylinder (10).

Turn the knurled collar on the Chisel Holder (31) until the retaining ball is fully visible.

Insert the Chisel (32) into the Chisel Holder (31) and select the nearest position to align the blade with the Throttle Lever (7).

Turn the collar half a turn to lock the Chisel (32) in place.

If the Chisel (32) does not line up, it may require the Chisel Holder (31) to be unscrewed slightly.

Tighten the pinch bolt (30) using a 6mm AF Allen key. To release the Chisel (32), rotate the knurled collar until the retaining ball is fully visible and remove the Chisel (32).

Needle Holder Attachment

Before fitting the Needle Scaler Attachment, disconnect the air supply to the tool.

Assemble the component parts of the Needle Scaler attachment in the following order; insert the Needles (26) into the Needle Holder (25), place the Spring (27) over the Needles,

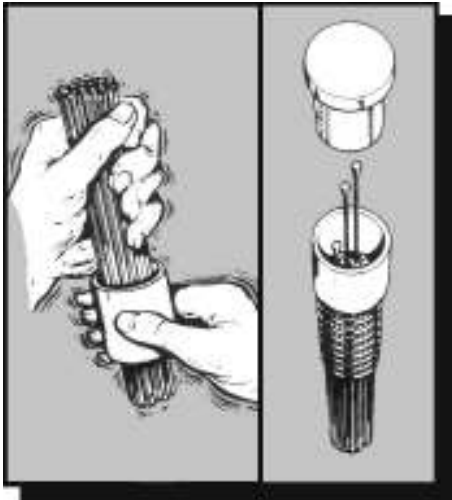

Hold the needles loosely and shake the holder, needles will fall into location holes

The correct position of parts when changing needles

insert the Anvil (24) into the Needle Holder (25), then place the assembly into the Intermediate Tube (28). Check the service layout for clarification. Screw the assembly fully onto the Cylinder (10) and tighten the pinch bolt (30) using a 6mm AF Allen key.

Slide the Front Tube (29) on to the Intermediate Tube (28) until approximately 25mm (1") of Needle protrudes from the Front Tube (29). Tighten the pinch bolt (30) using a 6mm AF Allen key.

As the Needles wear, adjust the Front Tube by loosening the Allen Screw and adjusting the Front Tube so that approximately 1" (25mm) of Needle protrudes from the Front Tube (29) and then retighten the Allen Screw.

Pointed tip needles

Sharpened to a nail point, these are most effective in breaking through very hard scale on surfaces where some surface indentation is permissible - or where keying (i.e. profile) of the surface is desirable.

Pointed tip needles are available in 3mm and 4mm only.

Chisel tip needles

These are general purpose needles, flattened to a chisel like blade and are most effective in the removal of thicker material, while leaving a less pitted surface than the Pointed tip needles but still giving some surface indentation (i.e. profile).

Chisel tip needles are available in 3mm only.

Flat tip needles

Machined to a flat tip, these needles will leave slight marking (i.e. profile) on the surface; the 2mm needles can have a burnishing effect. 2mm Needles are recommended for use on thin gauge metals and any surface where light treatment is desired.

Flat tip needles are available in three sizes - 2mm, 3mm and 4mm.

Maintenance

Only a competent person, in a suitably equipped workshop, must carry out maintenance.

Disconnect the tool from the air supply before carrying out any maintenance or any of the operations in the next sections.

Clean all debris from the exterior of the tool.

Cleaning

At intervals of no more than 40 hours or if operation becomes unproductive and the Piston shows signs of sticking, dismantle and clean with a highly refined paraffin.

Replace worn components as necessary.

Immediately after cleaning, thoroughly oil the tool with one of the recommended lubricants.

Piston and Cylinder Removal

Remove the Chisel Holder (31) or Needle Attachment as previously described. Clamp the Cylinder (10) firmly in a vice using the flats provided. Using a suitable wrench and the spanner flats provided, unscrew the Cover (14) from the Cylinder (10). This may initially need some extra effort to break the bond. With the Cylinder (10) free of the Cover, push the Piston (9) out of the Cylinder (10).

Remove the Cylinder (10) from the vice and inspect all parts for wear, particularly the Piston (9) and the Cylinder's bores. Remove the two O' Rings (11)(12) from the Cylinder (10).

Valve Body Servicing

Clamp the Valve Body Assembly firmly in a vice at the Valve Body (6) using the flats provided, with the Throttle Lever (7) uppermost. Using a 3mm diameter pin punch and small hammer, remove the Throttle Lever Roll Pin (8), and remove the Throttle Lever (7). Rotate the Valve Body (6) 180 degrees in the vice to gain access the Valve Cap (1). Unscrew the Valve Cap (1) using a screwdriver, check the Valve Cap 'O' Ring (2) for signs of deterioration, remove the Spring (3), push out the Valve Stem (4) and remove the valve seat 'O' Ring (5). Check the Valve Stem (4) and 'O' Ring (5) for wear.

Assembly

Before any assembly takes place, ensure all parts are clean and are coated in a thin film of recommended air tool lubricant.

It is strongly recommended that all the O'Rings and any other worn parts be replaced using only genuine Trelawny spares.

Valve Body Assembly

Clamp the Valve Body firmly in a vice, using the flats provided, and with the threaded hole uppermost.

Insert the valve seat 'O' Ring (5) into Valve Body (6), followed by the Valve Stem (4), Spring (3), then the Valve Cap (1) complete with its 'O' Ring (2), tighten the Valve Cap (1) with a screwdriver.

Rotate assembly 180 degrees in the vice. Using a 3mm diameter pin punch locate and align the Throttle Lever (7) in position, then drive in the Throttle Lever Roll Pin (8) into the pin location.

Piston and Cylinder Assembly

Fit new O'Rings (11)(12) to the Cylinder (10), Lubricate the Piston (9) and Cylinder bore, insert the Piston (9) into the Cylinder bore. Ensure that the threads on the Cylinder (10) and in the Cover are clean and dry.

Clamp the Cylinder (10) in a vice using the flats provided.

Then using a suitable wrench on the spanner flats provided, tighten the Cover onto the Cylinder (10) and torque to 135Nm (100lbs/ft). Refit the Chisel Holder/Needle Scaling Attachment as described previously.

Recommended Lubricants

Oil the tool daily before use. Put a few drops of one of the following zinc free air tool lubricants through the air inlet.

SHELL	S22 or R10
CASTROL	Hyspin ZZ32

Disposal

When the tool and its accessories are taken out of service for disposal, it is recommended that: -

They are rendered unusable to prevent improper re-use.

They are dismantled into component form, segregated according to material composition and disposed of using waste recycling processes specified by local regulations.

Machinery Directive Information

This tool has been designed and produced in accordance with the following directive:

2006/42/EC Machinery Directive

SERVICE LAYOUT - Standard Scaler

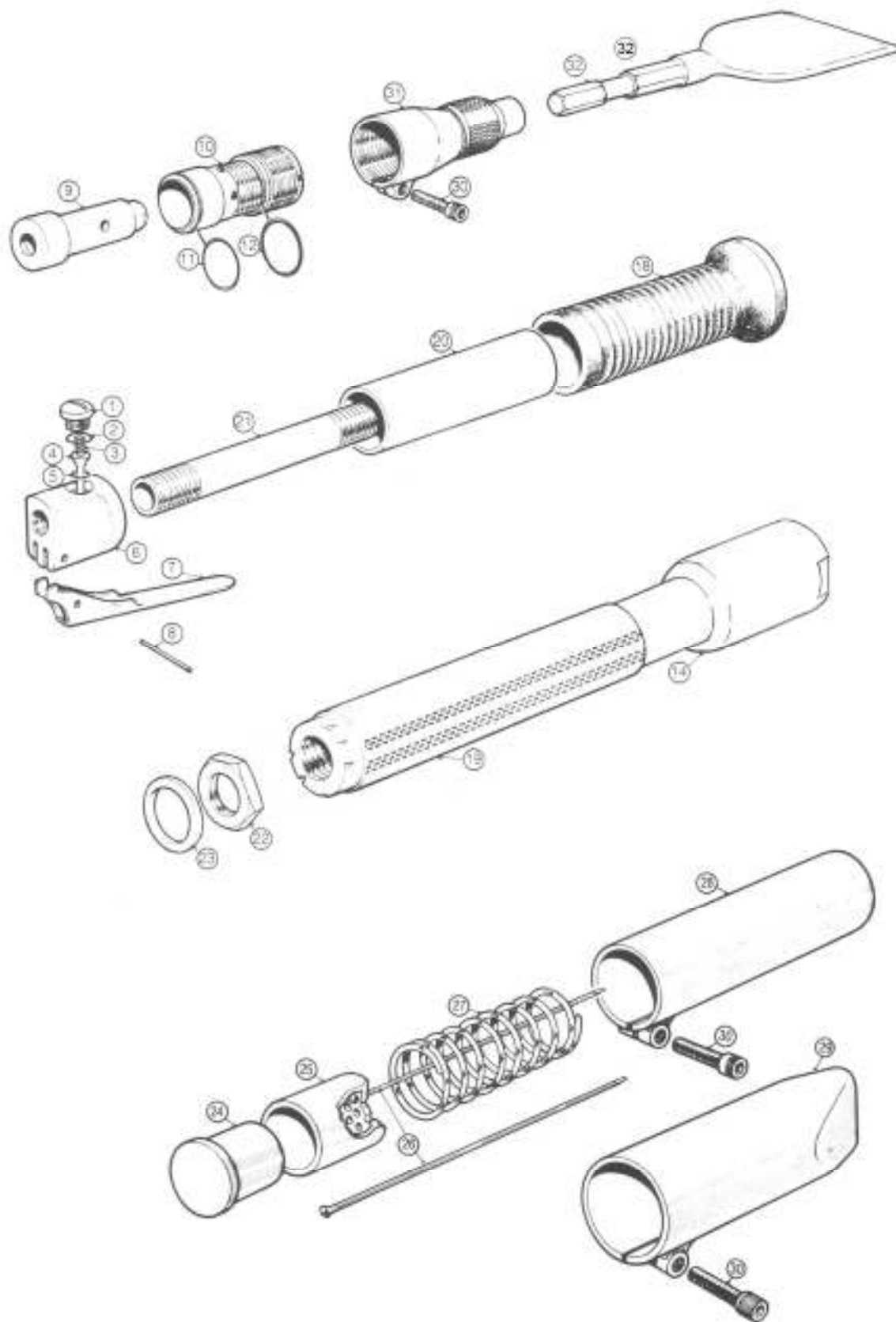

SERVICE LAYOUT - Lite Scaler

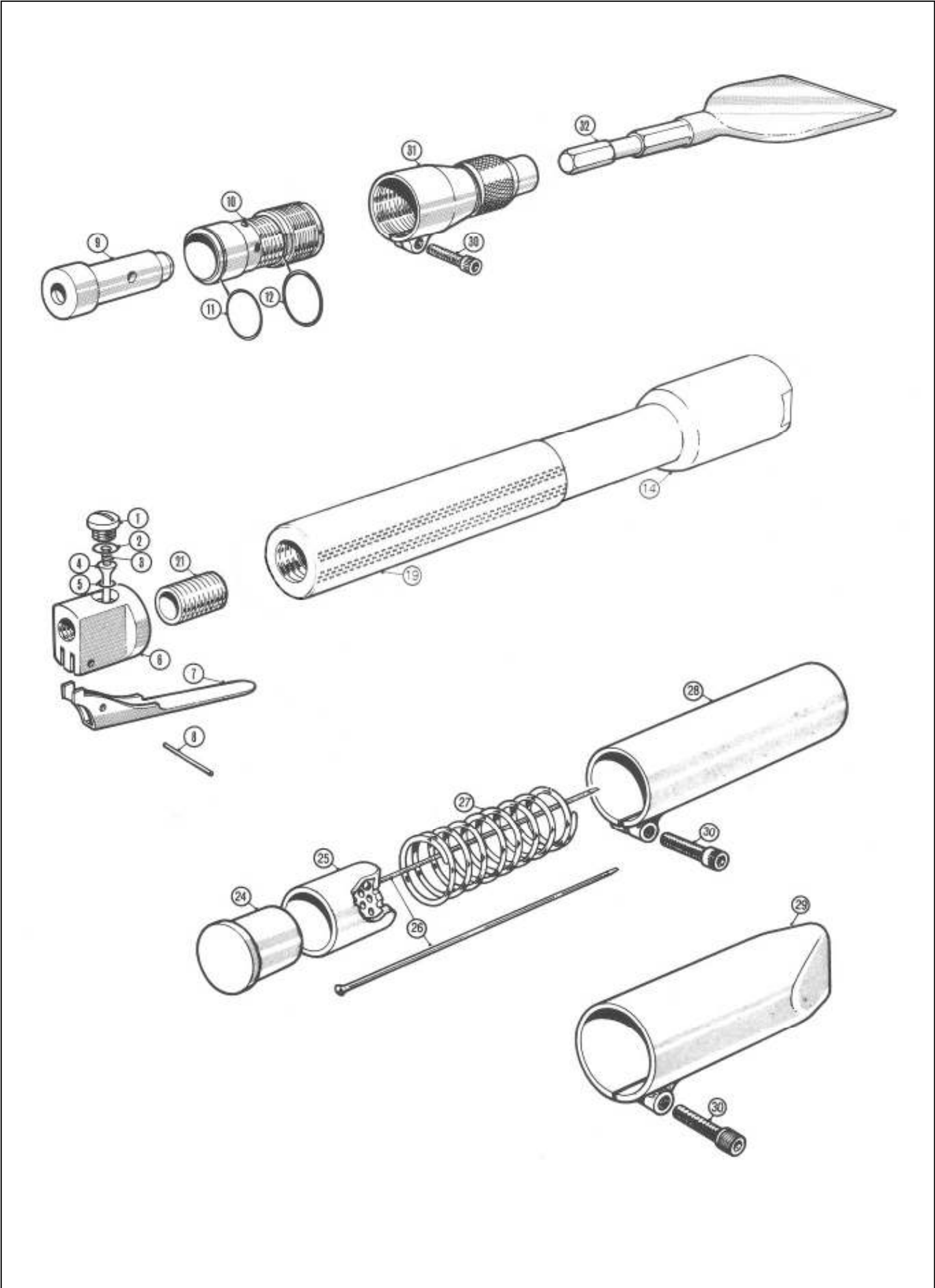

PARTS LIST

ITEM	PART No	DESCRIPTION	ITEM	PART No	DESCRIPTION
Common components			Common components		
1	615.3021	Valve Cap	30	806.0830	Cap Head Screw
2	809.0139	O'Ring (Valve Cap)	31	419.3541	Chisel Holder Assembly 5/8" Hex
3	712.3022	Valve Spring	32	705.1102	Chisel 5/8" Hex 8" Long x 4" Blade
4	618.3022	Valve Stem		431.3504	Scraper Holder - includes 4" Replaceable Blade
5	809.0089	O'Ring - (Valve Seat)		431.3508	Scraper Holder - inc 8" Replaceable Blade
6	616.3021	Valve Body		431.3512	Scraper Holder - inc 12" Replaceable Blade
	423.3021	Valve Body Assembly (Comprises items 1-8)		431.3904	Scraper Holder - inc Bevelled 4" Replaceable Blade
7	713.3021	Throttle Lever		431.3908	Scraper Holder - inc Bevelled 8" Replaceable Blade
8	813.0108	Roll Pin		431.3912	Scraper Holder - inc Bevelled 12" Replaceable Blade
9	612.3001	Piston		439.3504	Pack of 5 Scraper blades 4"
10	613.3101	Cylinder		439.3508	Pack of 5 Scraper blades 8"
11	809.0289	O'Ring (Cylinder -small diameter)		439.3512	Pack of 4 Scraper blades 12"
12	809.0299	O'Ring (Cylinder -large diameter)		439.3524	Pack of 5 Bevelled Scraper blades 4"
24	610.3001	Anvil		439.3528	Pack of 5 Bevelled Scraper blades 8"
25	601.3003	2mm Needle Holder		439.3522	Pack of 5 Bevelled Scraper blades 12"
	601.3002	3mm Needle Holder		705.1100	Chisel 5/8" Hex 9" Long x 2" Blade
	601.3004	4mm Needle Holder		705.1101	Chisel 5/8" Hex 9" Long Spark Resistant 1" Blade
26	412.1165	6 x 2mm Needle Sets (Flat Tip)		705.1106	Chisel 5/8" Hex 9" Long x 2" Blade
	413.2128	6 x 3mm Needle Sets (Chisel Tip - standard fitment)		705.1112	Chisel 5/8" Hex 8" Long Spark Resistant 4" Blade
	413.1128	6 x 3mm Needle Sets (Flat Tip)		705.2100	Chisel 5/8" Hex Cranked 11" Long x 1 3/8" Blade
	413.3128	6 x 3mm Needle Sets (Pointed Tip)		705.2102	Chisel 5/8" Hex 8" Long x 4" Cranked Blade
	403.1328	1 x 3mm Needle Sets (Beryllium Copper)		708.1100	Comb Holder 5/8" Hex for 1 1/2" Steel Comb
	414.2119	6 x 4mm Needle Sets (Chisel Tip)		708.1101	Comb 1 1/2" Wide
	414.1119	6 x 4mm Needle Sets (Flat Tip)		641.3512	Yoke for Scraper Blades (no blade)
	414.3119	6 x 4mm Needle Sets (Pointed Tip)		806.0816	Button Head Screw for Yoke/Scraper Blade
	442.1107	Pack of 2000 2mm Needles (Flat Tip)		824.0800	Nyloc Nut for Yoke/Scraper Blade
	452.1110	Pack of 100 2mm Needles (Flat Tip)			
	443.2107	Pack of 1000 3mm Needles (Chisel Tip)	Long Reach components (Standard tool)		
	443.1107	Pack of 1000 3mm Needles (Flat Tip)	14	425.3225	2' Cover std
	443.3107	Pack of 1000 3mm Needles (Pointed Tip)		425.3425	4' Cover std
	443.1307	Pack of 500 3mm Needles (Beryllium Copper)		425.3525	5' Cover std
	453.2110	Pack of 100 3mm Needles (Chisel Tip)		425.3625	6' Cover std
	453.1110	Pack of 100 3mm Needles (Flat Tip)	18	717.3011	Rubber Handle Grip
	453.3110	Pack of 100 3mm Needles (Pointed Tip)	19	717.3501	Cover Grip
	453.1310	Pack of 100 3mm Needles (Beryllium Copper)	20	624.3001	Handle Tube
	444.2107	Pack of 500 4mm Needles (Chisel Tip)	21	623.3001	Centre Tube
	444.1107	Pack of 500 4mm Needles (Flat Tip)	22	625.3001	Locknut
	444.3107	Pack of 500 4mm Needles (Pointed Tip)	23	810.9000	Sealing Washer
	454.2105	Pack of 50 4mm Needles (Chisel Tip)			
	454.1105	Pack of 50 4mm Needles (Flat Tip)	Long Reach components (Lite tool)		
	454.3105	Pack of 50 4mm Needles (Pointed Tip)	14	425.3498	4' Lite Cover
27	712.3001	Compression Spring		425.3598	5' Lite Cover
28	416.3132	Intermediate Tube		425.3698	6' Lite Cover
29	417.3032	Front Tube (Straight)	19	717.3501	Cover Grip
	418.3032	Front tube (Round)	21	627.3598	Threaded Adapter
	415.3532	Needle Scaler Assembly (Items 24 to 28)			

SPECIFICATION

Model Type	LR2	LR4	LR4 Lite	LR5	LR5 Lite	LR6	LR6 Lite
Piston Diameter	28.6mm	28.6mm	28.6mm	28.6mm	28.6mm	28.6mm	28.6mm
Piston Stroke	39mm	39mm	39mm	39mm	39mm	39mm	39mm
Blows per Minute	2200	2200	2200	2200	2200	2200	2200
Air Consumption	2.1lps (4.5cfm)	2.1lps (4.5cfm)	2.1lps (4.5cfm)	2.1lps (4.5cfm)	2.1lps (4.5cfm)	2.1lps (4.5cfm)	2.1lps (4.5cfm)
Air Inlet	1/4" BSP (c/w 1/4" BSP to 3/8" hose tail)						
Overall Length	740mm (29")	1100 (43")	1100 (43")	1400mm (55")	1400mm (55")	1710mm (67")	1710mm (67")
Nett Weight	3.7kg (8.2lbs)	4.9kg (10.8lbs)	3.0kg (6.6lbs)	5.5kg (12.2lbs)	3.4kg (7.5lbs)	6.1kg (13.5lbs)	3.8kg (8.4lbs)
Noise Level Lpa db(A) - Chisel Scaler	81.3	80.5	85.8	82.4	81.2	84.3	84.2
Noise Level Lpa db(A) - Needle Scaler	103.1	103.5	104.7	103	104.5	103.5	104.5
Noise Level Lwa db(A) - Chisel Scaler	94.3	93.5	98.8	95.9	-	-	-
Noise Level Lwa db(A) - Needle Scaler	116.1	117.7	116.5	116	117.5	116.5	117.5
Vibration Level AEQ - Needle Scaler H1* (k)**	4.0	8.9	13.0	11.4	10.3	7.7	10.4
Vibration Level AEQ - Needle Scaler H2* (k)**	5.4	9.5	13.2	10.1	10.8	9.8	11.6
Vibration Level AEQ - Chisel Scaler H1* (k)**	15.3	11.7	25.1	12.3	19.3	12.5	16.2
Vibration Level AEQ - Chisel Scaler H2* (k)**	12.9	12.2	19.2	11.8	18.7	12.2	18.8

H1* Indicates that the test was taken at the primary handgrip location, next to the throttle lever.
H2* Indicates that the test was taken at the secondary handgrip position.

Noise level measured in accordance with: EN ISO 15744: 1999

Risk of Hand Arm Injury

(k) ** Equals the factor of uncertainty, which allows for variations in measurement and production. Vibration Data figures are tri-axial, which gives the total vibration emission.

Because of various factors, the range of vibration emission during intended use of these tools is expected to be between 4m/s² and 35.2m/s² dependent on the tool purchased. The vibration is dependent on the task, the operators grip, and feed force employed etc.

NOTE: The above vibration levels were obtained from tri-axial measurements to comply with the requirements of "The Control of Vibration at Work Regulations 2005*" and in anticipation of the revisions to the 8662 (28662) series of standards. These values are at least 1.4 times larger than the values obtained from single axis measurements.

*Based on European Union Council Directive 2002/44/EC (Physical Agents (Vibration) Directive)

If your company has any problem with our products or would like to discuss the possibility of an improvement being made to them, then please do not hesitate to contact us. Your comments are both important and appreciated.

All rights reserved. Any unauthorised use or copying of the contents or part thereof is prohibited.

This applies to trademarks, model denominations, part numbers and drawings.

Use only genuine Trelawny spares.

The use of non-Trelawny spare parts invalidates the warranty.



INVESTOR IN PEOPLE



MEMBER

TRELAWNY

SURFACE PREPARATION TECHNOLOGY



Trelawny SPT Ltd
Trelawny House, 13 Highdown Road, Sydenham Industrial Estate, Leamington Spa, Warwickshire,
CV31 1XT, United Kingdom
Telephone: +44 (0)1926 883781
Fax: +44 (0)1926 450352
Email: sales@trelawny.co.uk
General Industry Website: www.trelawnyspt.com
Dedicated Marine Website: www.trelawny-marine.com